

MANIACCESS

■ **80 VJR**
105 VJR

Very effective and easy to transport



 **MANITOU**

80 VJR

 **Safe working load**200 kg
Inside use only

 **Working height**7.90 m
Platform height5.90 m

 **Overall length**2.81 m
Overall width0.99 m
Overall height1.99 m
Outreach3.30 m
Basket size0.99 m X 1.05 m
Ground clearance8.5 cm
Turning radius :
 inside0.52 m
 outside2.02 m

 **Turret rotation**350°
Jib tilting140°

 **Traction battery**24 v/180 Ah (C5)
Integrated charger24 v/30 A

Travel speed0 to 3.6 km/h
Number of speeds3

 **Gradeability**28 %
Max. slope accepted2° or 3.5 %

 **Tyres**18.7/8 PPS
 2 wheel drive (Rear) and 2 steering wheel (front)

Hydraulic tank28 L.

 **Weight**2400 kg

105 VJR

 **Safe working load**200 Kg
Outside useSWL 200 Kg
Winds up to45 km/h

 **Working height**10.30 m
Platform height8.30 m

 **Overall length**2.81 m
Overall width0.99 m
Overall height1.99 m
Outreach3.30 m
Basket size0.99 m X 1.05 m
Ground clearance8.5 cm
Turning radius :
 inside0.52 m
 outside2.02 m

 **Turret rotation**350°
Jib tilting140°

 **Traction battery**24 v/270 Ah (C5)
Integrated charger24 v/30 A

Travel speed0 to 3.6 km/h
Number of speeds3

 **Gradeability**22 %
Max. slope accepted3° or 5 %

 **Tyres**18.7/8 PPS
 2 wheel drive (Rear) and 2 steering wheel (front)

Hydraulic tank28 L.

 **Weight**3280 kg

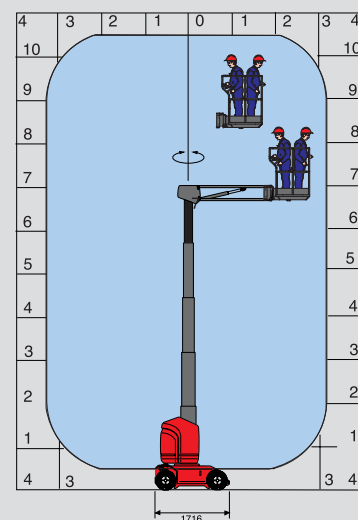
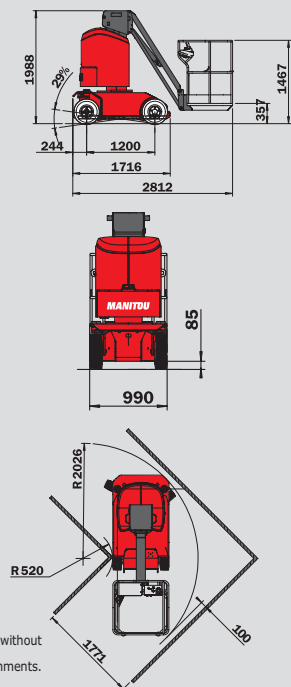
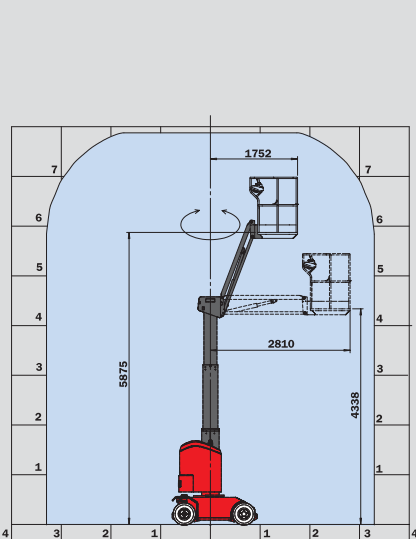

This publication in no way constitutes an offer and the company reserves the right to alter specification without prior notice.
 The MANITOU models presented in this brochure can be supplied complete with optional equipment attachments.



MANITOU BF SA
 B.P. 249 - 44158 Ancenis Cedex - France
 Tél. : 33 2 40 09 10 11 / Export Department Fax : 33 2 40 09 10 97
 www.manitou.com

